

WALL LOUVER SYSTEM

ALUMINUM. IMPACT RESISTANT.



MIAMI-DADE COUNTY, FLORIDA
NOA NO. 15-0218.08
EXPIRATION DATE 6/30/2020
APPROVAL DATE 6/25/2015

PARTS:

1. WALL SUBSTRATE (3000 PSI MIN. CONCRETE STRUCTURE TYPICAL)
2. INSTALLATION WOOD BUCK (IF NECESSARY)
3. ANCHORAGE-A MOUNTING POSITION (SEE CHART)
4. ALUMINUM LOUVER
5. 1/2"-14 THREADED ZINC COATED ROD. WASHER AND NUT AT BOTH ENDS
6. SILICONE BUILDING SEALER BY DOW CORNING PRODUCT #795
7. 3/4" EXPANDED ALUMINUM BIRD SCREEN
8. 2" X 1" X 1/8" ALUMINUM L-BAR REINFORCEMENT BRACKET REQUIRED ON UNITS OVER 30" WIDE

NOTES:

1. LOUVERS ARE TO BE INSTALLED IN A LOCATION WHICH IS DESIGNED TO DRAIN WATER PENETRATING THE ROOM, AND WILL HOUSE WATER RESISTANT OR WATER PROOF EQUIPMENT, COMPONENTS AND/OR SUPPLIES.
2. CHECK ALL SIDES OF INSTALLATION OPENING FOR STRAIGHTNESS. REPAIR ANY CRACKS OR VOIDS IN SUBSTRATE.
3. INSURE THAT BUCKS ARE CONTINUOUS AROUND THE OPENING AND ARE PLUMB, LEVEL AND SQUARE. THE BUCKS SHOULD BE SEALED TO THE WALL WITH GOOD QUALITY CAULKING.
4. WOOD BUCKS (BY INSTALLER) MUST SUSTAIN LOADS IMPOSED BY THE LOUVER SYSTEM AND TRANSFER THEM TO THE BUILDING STRUCTURE.
5. INSTALLATION MUST COMPLY WITH INSTRUCTIONS TO MEET MIAMI-DADE PRODUCT STANDARDS.
6. INSTALLER MUST APPLY FULL COVERAGE DOW 795 SILICONE BETWEEN SLEEVE FRONT FLANGE TO SUBSTRATE, AND LOUVER FRONT FLANGE TO SUBSTRATE AND/OR SLEEVE.

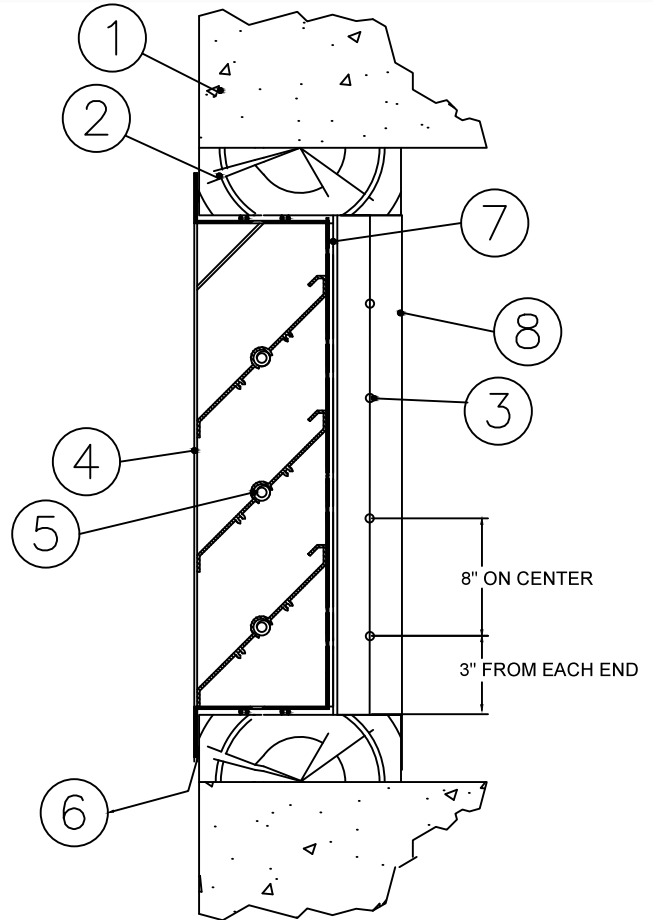

INSTALLING TO CONCRETE WITH BUCK

INSTALLING TO CONCRETE WITHOUT BUCK

INSTALLING TO WOODEN FRAME

INSTALLING TO METAL FRAME

<p>1/4" TAPCONS: MUST PENETRATE LOUVER AND BUCK 1.5" MIN. EMBEDMENT INTO 3,000 PSI CONCRETE 2.5" MIN. EDGE DISTANCE</p>	<p>1/4" TAPCONS 1.5" MIN. EMBEDMENT INTO 3,000 PSI CONCRETE 2.5" MIN. EDGE DISTANCE</p>	<p>#14 F.H.W.S. 1.5" MIN. EMBEDMENT INTO 2" THICK WOOD FRAME 2.5" MIN. EDGE DISTANCE</p>	<p>5/16" 24 X 2" HILTI KWIK FLEX SELF-DRILLING SCREW 12-GAUGE MIN. WALL THICKNESS STEEL MUST CONFORM WITH A500, A653 OR A36</p>

WLF-DA15

ALUMINUM WALL LOUVER SYSTEM INSTALLATION INSTRUCTIONS

NOTE: ALL DRAWINGS SUBJECT TO CHANGE WITHOUT PRIOR NOTICE.



Grille tech inc.

DRAWN BY: CG

DATE: 09/01/05

SCALE: NOT TO SCALE

DRAWING NO.

CHECKED BY: IV

DATE: 6/30/15

REVISION: 03

WL103-A

WALL LOUVER SYSTEM

ALUMINUM. IMPACT RESISTANT.



MIAMI-DADE COUNTY, FLORIDA
NOA NO. 15-0218.08
EXPIRATION DATE 6/30/2020
APPROVAL DATE 6/25/2015

STEP 1

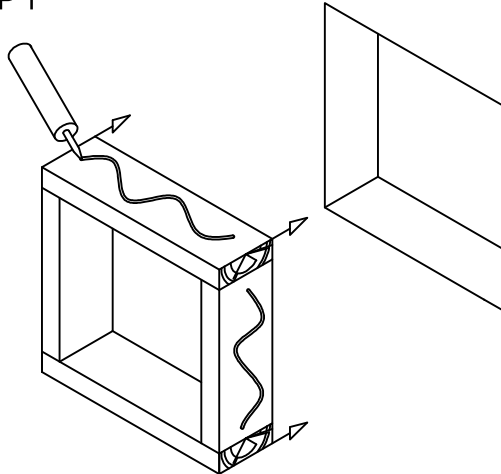

STEP 2

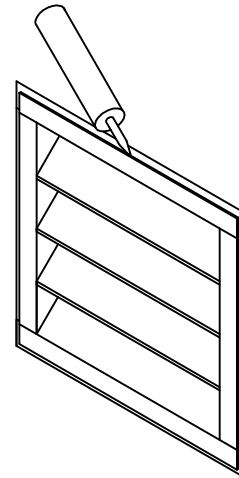

STEP 3

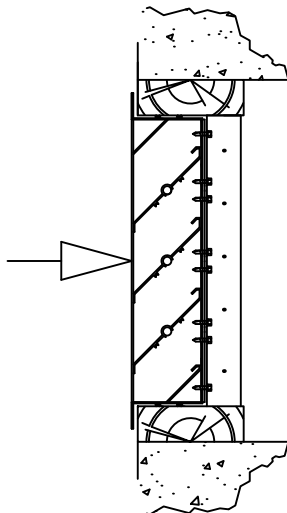

STEP 4

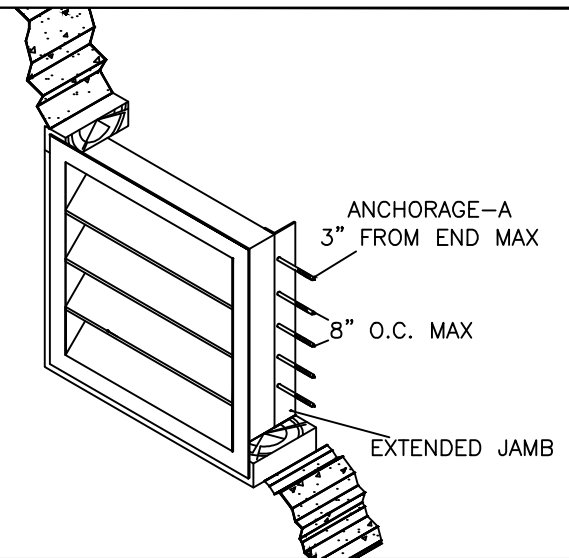

INSTALLATION INSTRUCTIONS: SINGLE UNIT APPLICATIONS

STEP 1:
PLACE INSTALLATION BUCK INSIDE THE PERIMETER OF THE OPENING. BE SURE IT IS TIGHT ON ALL SIDES AND SEALED TO THE WALL WITH CAULK. (IF LOUVER FITS TIGHTLY IN THE OPENING, A BUCK MAY NOT BE NECESSARY)

STEP 2:
INSTALLER MUST APPLY FULL COVERAGE OF DOW CORNING SILICONE BUILDING SEALANT #795 BETWEEN THE INTERIOR SIDE OF LOUVER FLANGE AND THE WALL. AS MANDATED BY MIAMI-DADE COUNTY STANDARDS.

NOTE A:
WOOD BUCKS (BY INSTALLER) MUST SUSTAIN LOADS IMPOSED BY THE LOUVER SYSTEM AND TRANSFER THEM TO THE BUILDING STRUCTURE.

NOTE B:
INSTALLATION MUST COMPLY WITH INSTRUCTIONS TO MEET MIAMI-DADE PRODUCT STANDARDS.

STEP 3:
SLIDE LOUVER INTO OPENING FROM THE FRONT.

STEP 4:
WHEN LOUVER IS TIGHTLY IN THE OPENING, INSTALL ANCHORAGE-A THROUGH THE 2" EXTENDED JAMB. (THE ANCHORAGE MUST EMBED IN THE STRUCTURE ACCORDING TO THE CHART ON PAGE 7)

WLF-DA15

ALUMINUM WALL LOUVER SYSTEM SINGLE UNIT INSTALLATION INSTRUCTIONS

NOTE: ALL DRAWINGS SUBJECT TO CHANGE WITHOUT PRIOR NOTICE.



DRAWN BY:	CG	DATE:	09/01/05	SCALE:	NOT TO SCALE	DRAWING NO.:	WL103-B
CHECKED BY:	IV	DATE:	6/30/15	REVISION:	03		

WALL LOUVER SYSTEM

ALUMINUM. IMPACT RESISTANT.



MIAMI-DADE COUNTY, FLORIDA
NOA NO. 15-0218.08
EXPIRATION DATE 6/30/2020
APPROVAL DATE 6/25/2015

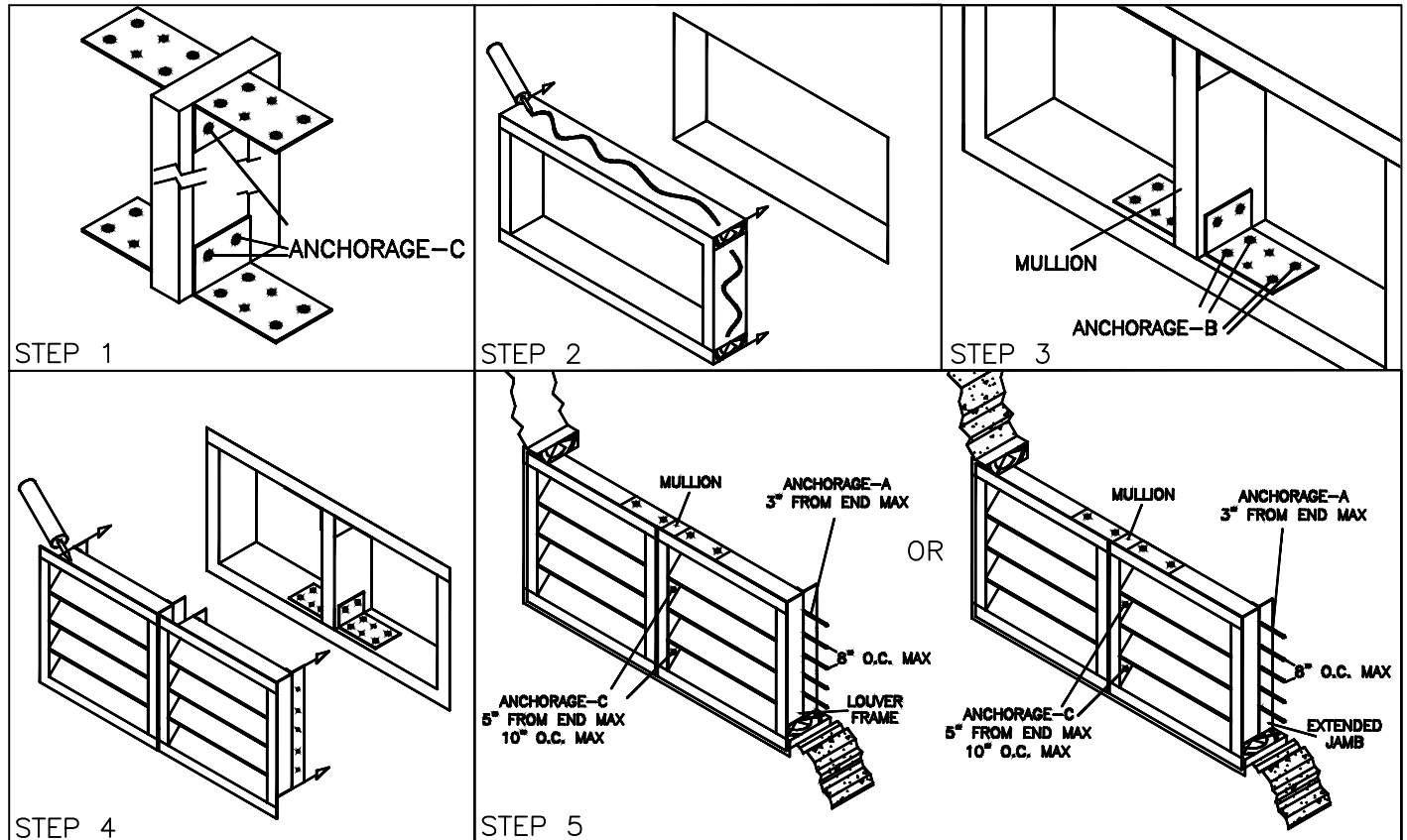

INSTALLATION INSTRUCTIONS: MULTIPLE UNIT APPLICATIONS

- STEP 1:**
ATTACH 4" X 4" X 1/8" MULLION CLIPS TO THE TOP AND BOTTOM OF THE ALUMINUM MULLION USING ANCHORAGE-C.
- STEP 2:**
PLACE INSTALLATION BUCK INSIDE THE PERIMETER OF THE OPENING. BE SURE IT IS TIGHT ON ALL SIDES AND SEALED TO THE WALL WITH CAULK. (IF LOUVERS FIT TIGHTLY IN THE OPENING, A BUCK MAY NOT BE NECESSARY.) IN BUCK APPLICATION, THE INSTALLER MUST FIELD INSTALL TWO ADDITIONAL HOLES PER MULLION CLIP AT MIDSPAN WHERE THE 1/8" HOLES ARE LOCATED. (AS PER DRAWING IN PAGE 5 OF 7 MULL CLIP TO SUBSTRATE)
- STEP 3:**
CENTER MULLION IN THE OPENING FLUSH TO THE FRONT AND ATTACH USING ANCHORAGE-B. (THE ANCHORAGE MUST EMBED IN THE STRUCTURE ACCORDING TO THE CHART ON PAGE 7)
- STEP 4:**
SLIDE LOUVERS INTO THE OPENING FROM THE FRONT. INSTALLER MUST APPLY FULL COVERAGE DOW 795 SILICONE BETWEEN SLEEVE FRONT FLANGE TO SUBSTRATE, AND LOUVER FRONT FLANGE TO SUBSTRATE AND/OR SLEEVE.
- STEP 5:**
WHEN LOUVERS ARE TIGHTLY IN THE OPENING, INSTALL ANCHORAGE-C THROUGH THE LOUVER FRAME INTO THE ALUMINUM MULLION, AND ANCHORAGE-A THROUGH THE LOUVER FRAME INTO THE STRUCTURE. (THE ANCHORAGE MUST BE EMBEDDED INTO THE STRUCTURE ACCORDING TO THE ANCHORAGE CHART ON PAGE 7)
- OR
- WHEN LOUVERS ARE TIGHTLY IN THE OPENING, INSTALL ANCHORAGE-C THROUGH THE LOUVER FRAME INTO THE ALUMINUM MULLION, AND ANCHORAGE-A THROUGH THE 2' EXTENDED JAMB INTO THE STRUCTURE. (THE ANCHORAGE MUST BE EMBEDDED INTO THE STRUCTURE ACCORDING TO THE ANCHORAGE CHART ON PAGE 7)

NOTE A:
WOOD BUCKS (BY INSTALLER) MUST SUSTAIN LOADS IMPOSED BY THE LOUVER SYSTEM AND TRANSFER THEM TO THE BUILDING STRUCTURE.

NOTE B:
INSTALLATION MUST COMPLY WITH INSTRUCTIONS TO MEET MIAMI-DADE PRODUCT STANDARDS.

WLF-DA15

ALUMINUM WALL LOUVER SYSTEM MULTIPLE UNIT INSTALLATION INSTRUCTIONS

NOTE: ALL DRAWINGS SUBJECT TO CHANGE WITHOUT PRIOR NOTICE.



DRAWN BY:	CG	DATE:	09/01/05	SCALE:	NTS	DRAWING NO.	WL103-C
CHECKED BY:	IV	DATE:	6/30/15	REVISION:	03		

HORIZONTAL MULLED CONDITION

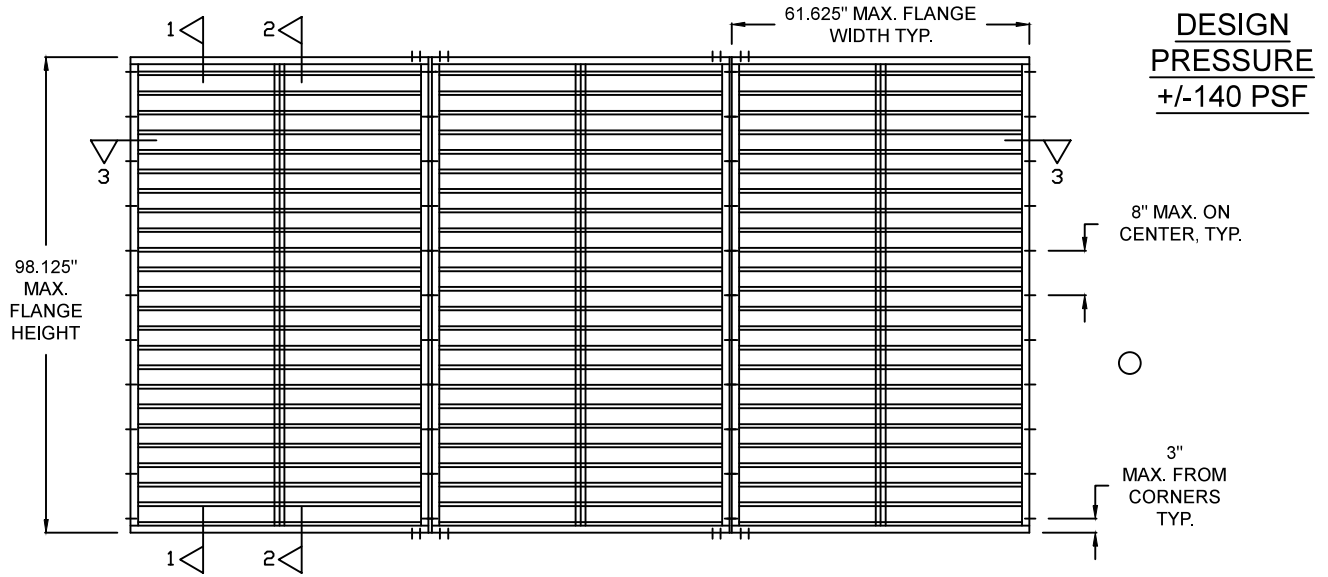

TWO-HIGH MULLED CONDITION

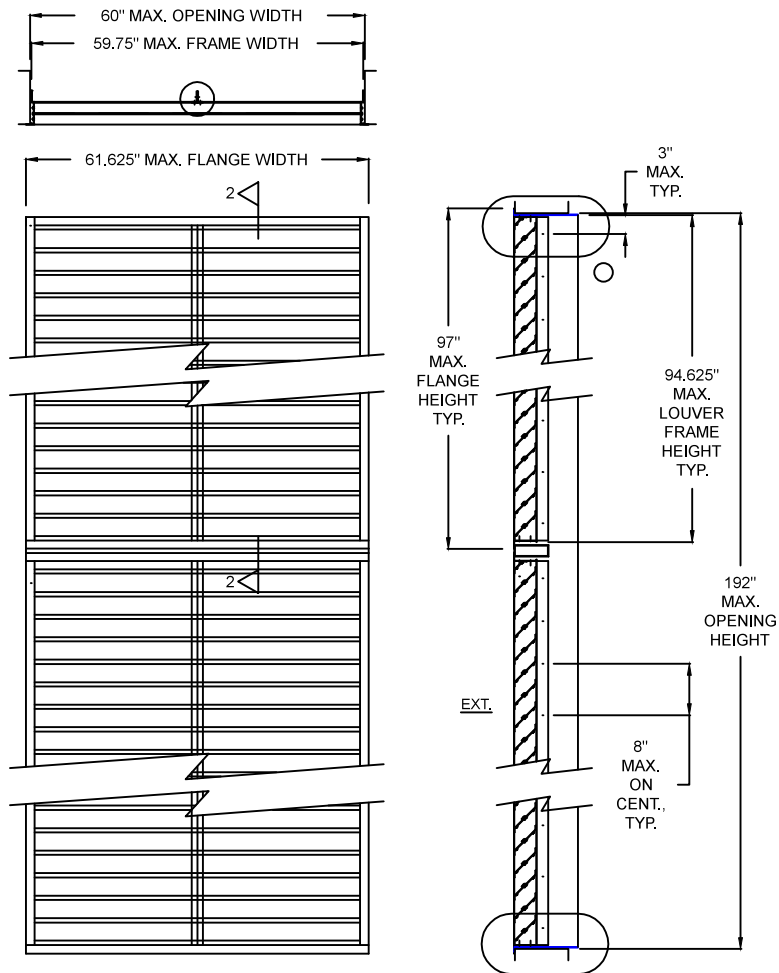

WLF-DA15

**ALUMINUM WALL LOUVER SYSTEM MULTIPLE UNIT
INSTALLATION INSTRUCTIONS**

NOTE: ALL DRAWINGS SUBJECT TO CHANGE WITHOUT PRIOR NOTICE.



DRAWN BY: CG	DATE: 09/01/05	SCALE: NTS	DRAWING NO. WL103-C
CHECKED BY: IV	DATE: 6/30/15	REVISION: 03	

WALL LOUVER SYSTEM

ALUMINUM. IMPACT RESISTANT.



MIAMI-DADE COUNTY, FLORIDA
NOA NO. 15-0218.08
EXPIRATION DATE 6/30/2020
APPROVAL DATE 6/25/2015

JAMB

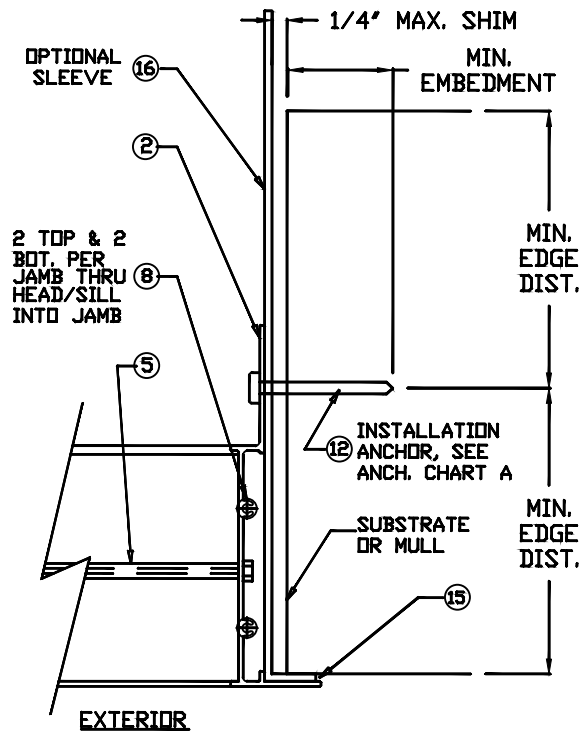

MULL CLIP TO SUBSTRATE AND JAMB TO MULL

ANCHORS SHOWN IN DASHED LINES FIELD-INSTALLED MID-SPAN OF PRE-PUNCHED LOCATIONS REQ'D FOR ANCHOR TYPE H INTO WOOD ONLY, SEE ANCHORAGE CHART B.

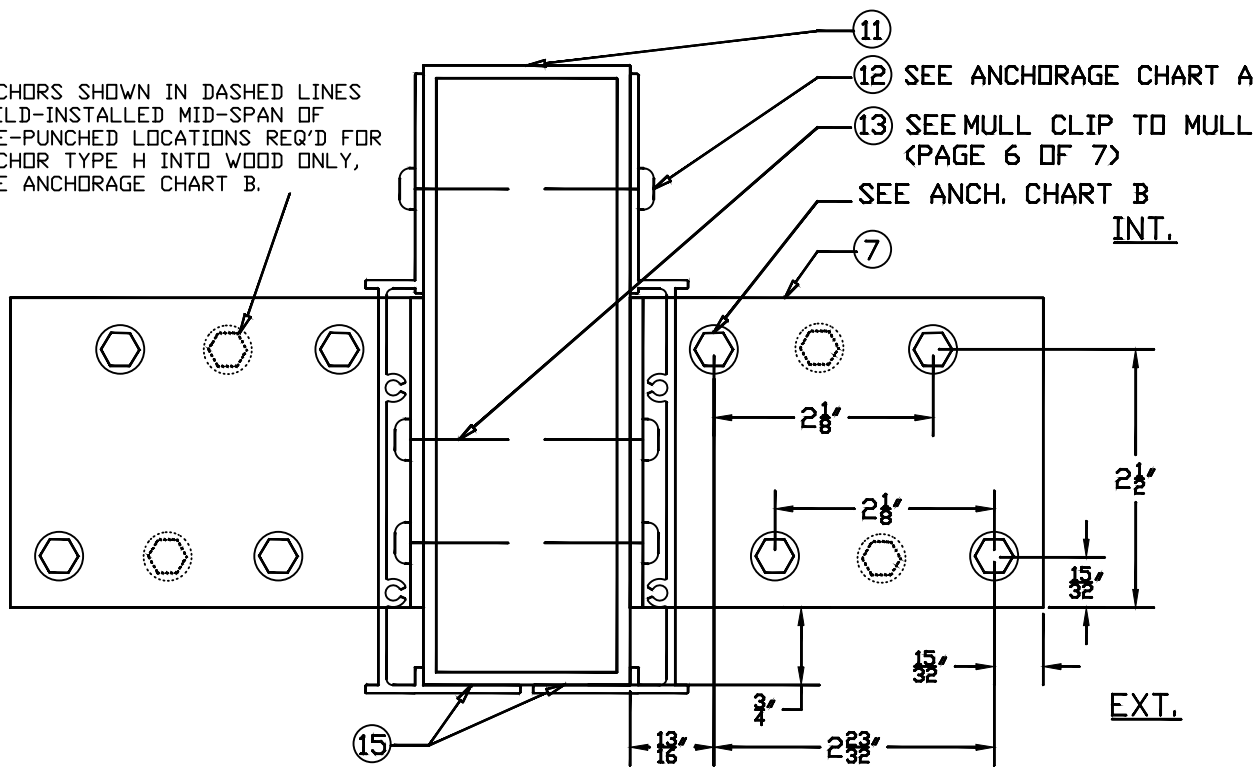

WLF-DA15

ALUMINUM WALL LOUVER SYSTEM MULTIPLE UNIT
INSTALLATION INSTRUCTIONS

NOTE: ALL DRAWINGS SUBJECT TO CHANGE WITHOUT PRIOR NOTICE.



DRAWN BY: CG	DATE: 09/01/05	SCALE: NTS	DRAWING NO.
CHECKED BY: IV	DATE: 6/30/15	REVISION: 03	WL103-C

MULL CLIP TO MULL

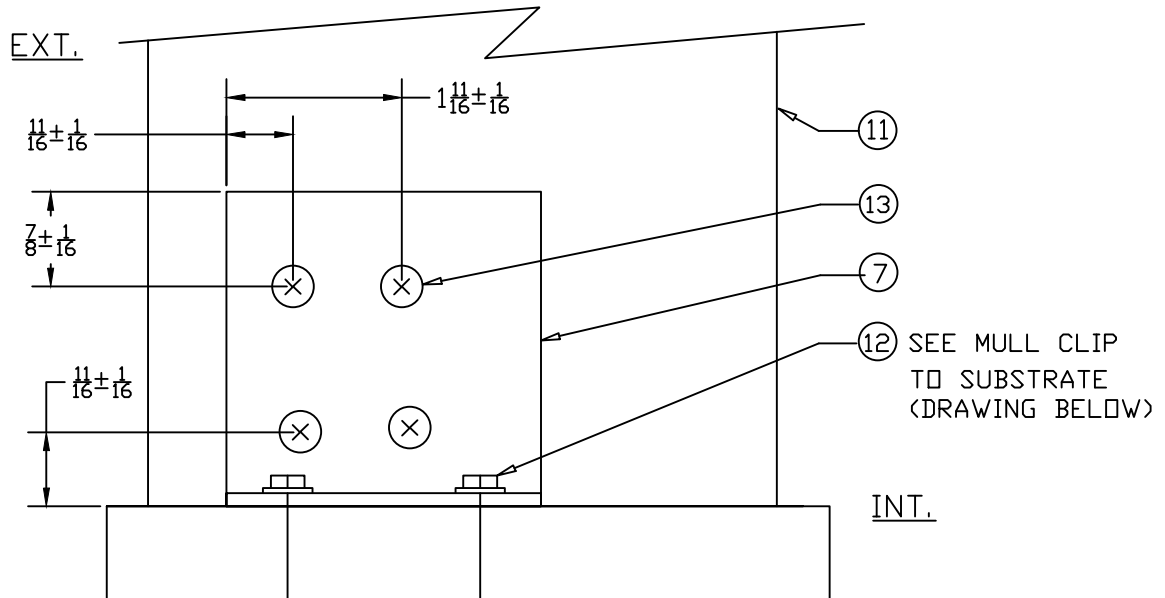

MULL CLIP TO SUBSTRATE

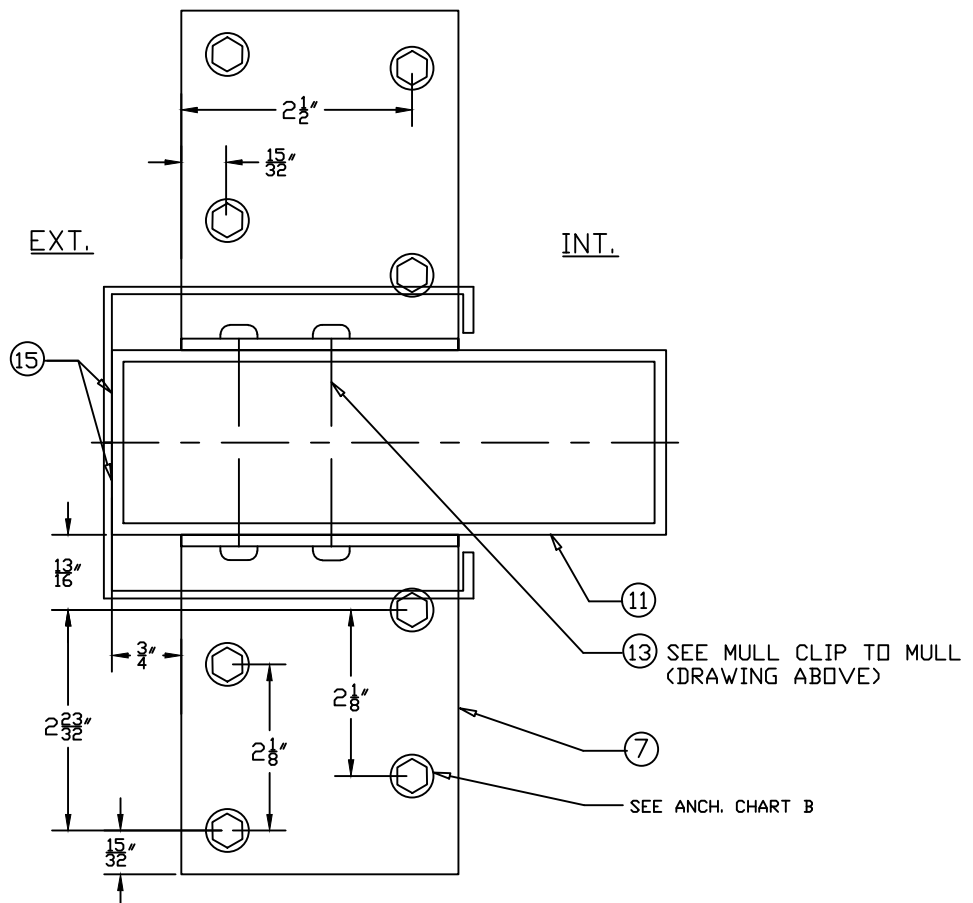

WLF-DA15

**ALUMINUM WALL LOUVER SYSTEM MULTIPLE UNIT
INSTALLATION INSTRUCTIONS**

NOTE: ALL DRAWINGS SUBJECT TO CHANGE WITHOUT PRIOR NOTICE.



DRAWN BY:	CG	DATE:	09/01/05	SCALE:	NTS	DRAWING NO.	WL103-C
CHECKED BY:	IV	DATE:	6/30/15	REVISION:	03		

WALL LOUVER SYSTEM

ALUMINUM. IMPACT RESISTANT.



MIAMI-DADE COUNTY, FLORIDA
NOA NO. 15-0218.08
EXPIRATION DATE 6/30/2020
APPROVAL DATE 6/25/2015

ANCHORAGE CHART A. QUALIFIED LOUVER INSTALLATION ANCHOR INFORMATION

ID	ANCHOR	SUBSTRATE	MIN. EMBED.	MIN. EDGE DISTANCE
A	1/4" ITW TAPCON	CONCRETE (3.2 KSI MIN)	1"	2 1/2"
B	1/4" ITW TAPCON	GROUT FILLED CMU	1 1/4"	2 1/2"
C	1/4" ITW TAPCON	WOOD (G=0.42 MIN)	1 3/8"	1"
D	#12 WOOD SCREW GRADE 5	WOOD (G=0.42 MIN)	1 3/8"	1"
E	#12 TEK SMS GRADE 5	1/8" ALUM. 6063-T5 MIN.	-	1/2"
F	#12 TEK SMS GRADE 5	1/8" STEEL 36 KSI MIN.	-	1/2"

ANCHORAGE CHART B. QUALIFIED MULLION CLIP ANCHOR INFORMATION

ID	ANCHOR	SUBSTRATE	MIN. EMBED.	MIN. EDGE DISTANCE	QTY PER CLIP
96" MAX. LENGTH VERTICAL MULLION, 61_5/8" MAX. LOUVER FLANGE WIDTHS					
G	5/16" ITW TAPCON	CONCRETE (2.9 KSI MIN)	2 1/4"	2 3/16"	4
H	#14 WOOD SCREW GRADE 5	WOOD (G=0.42 MIN)	2 1/2"	1"	6
I	#12 TEK SMS GRADE 5	1/8" STEEL 36 KSI MIN.	-	1/2"	4
60" MAX. LENGTH HORIZONTAL MULLION, 98_1/8" MAX. LOUVER FLANGE HEIGHTS					
A	1/4" ITW TAPCON	CONCRETE (3.2 KSI MIN)	1"	2 1/2"	4
D	#12 WOOD SCREW GRADE 5	WOOD (G=0.42 MIN)	1 3/8"	1"	4
F	#12 TEK SMS GRADE 5	1/8" STEEL 36 KSI MIN.	-	1/2"	4

ANCHORAGE CHART C. QUALIFIED MULLION CLIP ANCHOR INFORMATION

#12 P.P.H. X 1" TEK SHEET METAL SCEW

BILL OF MATERIALS

ITEM #	PART	DESCRIPTION	MATERIAL
1	4907A	FRAME HEAD AND SILL	6063-T5
2	5629	FRAME JAMB	6063-T6
3	4904	TOP BLADE	6063-T5
4	4903	BLADE	6063-T5
5		1/2"-14 ALL THREADED ZINC COATED ROD WITH WASHER AND NUT BOTH ENDS	AISI 1038
6	8149	1"X2"X1/8" (VERTICAL REINFORCING)	6063-T5
7		3"X4"X1/8" ANGLE, 3" LONG	6061-T6
8		#10 P.P.H. X 1" SHEET METAL SCEW	
9		#8 H.W.H X 3/4" SHEET METAL SCREW	
10		1/4"-20 X 3/4" ZINC COATED BOLT WITH NUT	
11	10-0086	2"X6"X1/8" ALUMINUM MULL	6061-T6
12		INSTALLATION ANCHOR, SEE ANCHORAGE CHART A.	
13		#12 P.P.H. X 1" TEK SHEET METAL SCEW	
14		#12 P.P.H. X 2" TEK SHEET METAL SCEW	
15		DOW 795 SILICONE BUILDING SEALANT	
16		SLEEVE: 0.85"X11.15"X1/8" FORMED FROM ALUM. SHEET	3003-H14

WLF-DA15

ALUMINUM WALL LOUVER SYSTEM MULTIPLE UNIT
INSTALLATION INSTRUCTIONS

NOTE: ALL DRAWINGS SUBJECT TO CHANGE WITHOUT PRIOR NOTICE.



DRAWN BY: CG	DATE: 09/01/05	SCALE: NTS	DRAWING NO. WL103-C
CHECKED BY: IV	DATE: 6/30/15	REVISION: 03	